

GPS Antenna Hoods

Technical Product Data

Features

- **Enclosed Environment, Eliminating The Need for GPS Repeaters**
- **L1 and L1/L2 Versions Available**
- **Optional 0-30dB Variable Atten.**
- **5in. and 8.75in. Versions Available**



Description

Complete end-to-end testing of GPS systems must, by definition, include the application's receive antenna. GPS Repeaters are a viable option where potential interference issues are not a concern. When a GPS Repeater is not an option, a viable and cost effective solution is the GPS Source Antenna Hood. At a fraction of the cost of a full blown screen room or chamber, the GPS Source Antenna Hood (GPSRH) will supply your application's receive antenna with the necessary GPS signals.

Operating in conjunction with an outdoor active antenna and a coaxial cable (cable type and length may be determined for appropriate signal loss), the GPS Source Antenna Hood with the power option will supply the necessary DC voltage to power the antenna and, with the 0-30dB Variable Attenuator option, provide a variable signal level to the application under test.

For more details please call, fax, email sales@gpssource.com, or visit our website www.gpssource.com for further information on product options & specifications.

Electrical Specifications, Operating Temperature -40 to 85⁰C

Parameter	Conditions	Min	Typ	Max	Units
Frequency Range: (Passband)	Ant – Output, Input = 50Ω	1570	1575	1580	MHz
Input Imped.			50		Ω
Input SWR	Input = 50Ω			2.5:1	-
Coupling	See Note 1		TBD		dB
DC Output V.	Powered OPTion	7.5	9	12	VDC
Current	Variable Atten. Option.			1	mA
Polarization	Right Hand Circular				

Notes:

1. GPS Antenna Hood-to-Application Antenna Coupling is a function of application antenna environment.

Part Number:

GPSRHL15 - V - P110/9 - SF

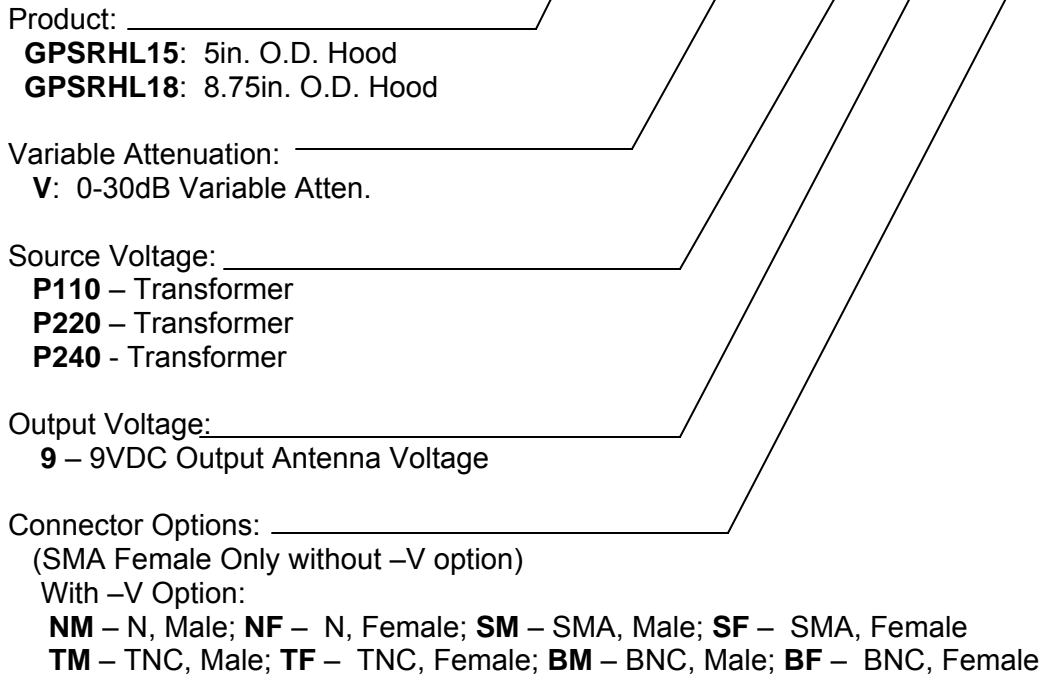

For help in creating the part number to meet your exact needs, contact us at Sales@gpssource.com or visit our website at www.gpssource.com .

Mechanical:

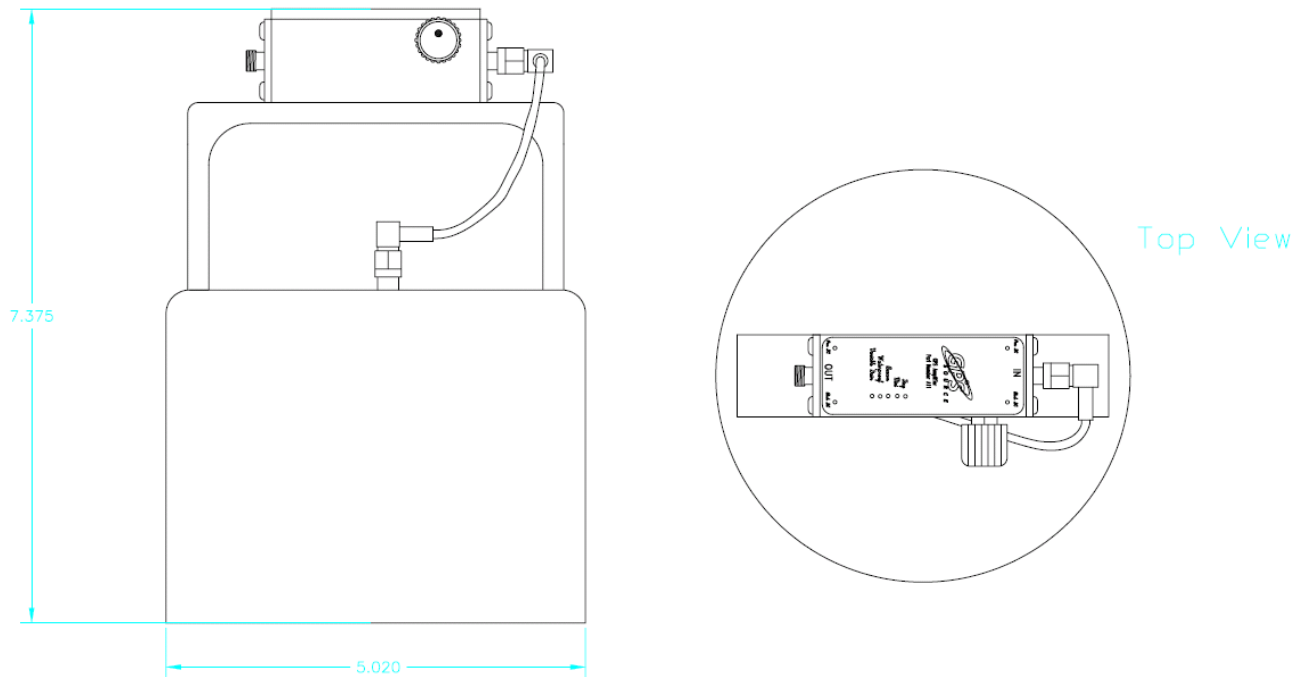

Figure 1. GPSRHL15: 5in. L1 Hood.